



TECHNICAL SPECIFICATION

Builders	Zhejiang Ouhua Shipbuilding Co., Ltd.
Year	2010
Type	Multipurpose
Flag	Liberia
Home port	Monrovia
IMO	9509683
Class	DNV- GL
Ice Class	None
Managers	Shanghai CP Int'l Shipmanagement & Broker Co.,Ltd.
Operators	Chinese-Polish Joint Shipping Company
P&I	PICC



TYPE	
Multipurpose Dry Cargo , Equipped for Carriage of Containers, Strengthened for Heavy Cargo, Removable Tweendecks, Semi Box Holds, Holds 2-4 convertible SID-TD	
DIMENSIONS	
Length	179.5 m
LPP	169.0 m
Beam	28.0 m
SDraft fully loaded	10.8 m
Air Draft	45.0 m
TONNAGE	
SDWT incl TWD	33271.0 mt
GT / NT	22863 / 10602
TANK CAPACITY	
HFO	1453.0 m <sup>3</sup>
MGO	474.0 m <sup>3</sup>
Ballast	12957.0 m <sup>3</sup>
Fresh Water	170.0 m <sup>3</sup>
CARGO GEAR	
MacGregor-Häggglunds electro hydraulic cranes	
4 x Cranes situated slightly port side of centre line	60,0 MT / 20,0 m
SWL/max. outreach	50,0 MT / 24,0 m
Gear combinable for Heavy lift	40,0 MT / 30,0 m
Attachments:	
1. Pocket plan of vessel presented as Single Decker (SID)	
2. Pocket plan of vessel presented as Tweendecker (TD)	

CARGO HOLDS	
Cargo Hold 1	
Tanktop	220.0 m <sup>2</sup>
Tweendeck N/A	N/A
Hatchcover	220.0 m <sup>2</sup>
Grain/Bale Capacity	3294 / 3255 cbm
Cargo Holds 2,3,4	
Tanktop	740,0 m <sup>2</sup>
Tweendecks, removable	740,0 m <sup>2</sup>
Hatchcover	680,0 m <sup>2</sup>
Grain/Bale Capacity	10765 / 10551 cbm
Cargo Hold 5	
Tanktop incl.monkey rocks	330,0 m <sup>2</sup>
Tweendeck	N/A
Hatchcover	350,0 m <sup>2</sup>
Grain/Bale Capacity	4248 / 4155 cbm
Permissible Loads	20,0 MT/m <sup>2</sup>
Tanktop	4,0 MT/m <sup>2</sup>
Tweendeck	4,0 MT/m <sup>2</sup>
Hatchcover	4,0 MT/m <sup>2</sup>
Hold Equipment	
CO2 Installed	YES
Grain (IMSBC)	YES
Dangerous Cargo (DG)	YES
A60 Bulkheads	NO
Sprinkler System	NO
Dehumidifier	NO
Air changes	6 exchanges per hour
Hatch type	Folding hydraulic type
Bow Thruster	NO
CONTAINER	
Container capacity, Reefer plugs	1158 TEU / 545 FEU, 30 reefer plugs
Stack weights	Holds - 150 mts per 20/40' stack
	Deck - 60/90 mts per 20/40' stacks

**MV CHIPOL YONGAN**  
( presented as single decker )

**CHIPOL CHANGAN**  
**CHIPOL BAOAN**  
**CHIPOL TAIAN**

**LOA : 179.5 MTR**  
**LPP : 169.0 MTR**  
**BR.M: 28.0 MTR**  
**DRAFT SUMMER: 10.80 MTR**

**DEADWEIGHT SUMMER : 32255 MT**

**GENERAL LOAD**

**TANKTOP : 20 MT/M2**

**HATCH COVER : 4 MT/M2**

**CONTAINER STACK LOAD**

	20'	40'
ABOVE ER	70T	56T
HATCH 1	28T	56T
HATCH 2-5	60T	90T
IN HOLDS	150T	150T

**HOLD CAPACITY**

No 1:	3341	M3
No 2:	10932	M3
No 3-4:	10959	M3
No 5:	4335	M3

**T-BEAM : SWL 109 MT**

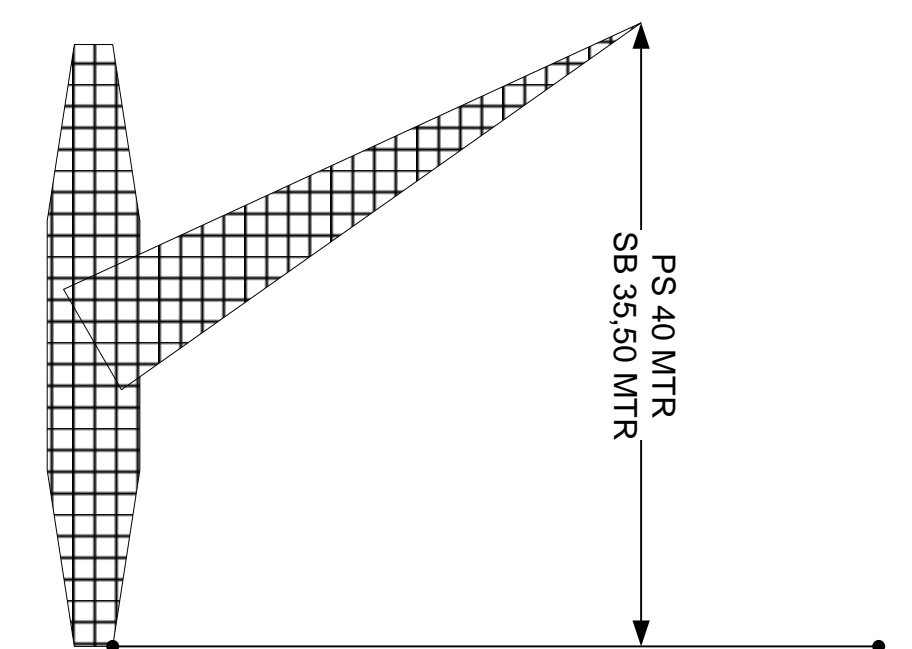
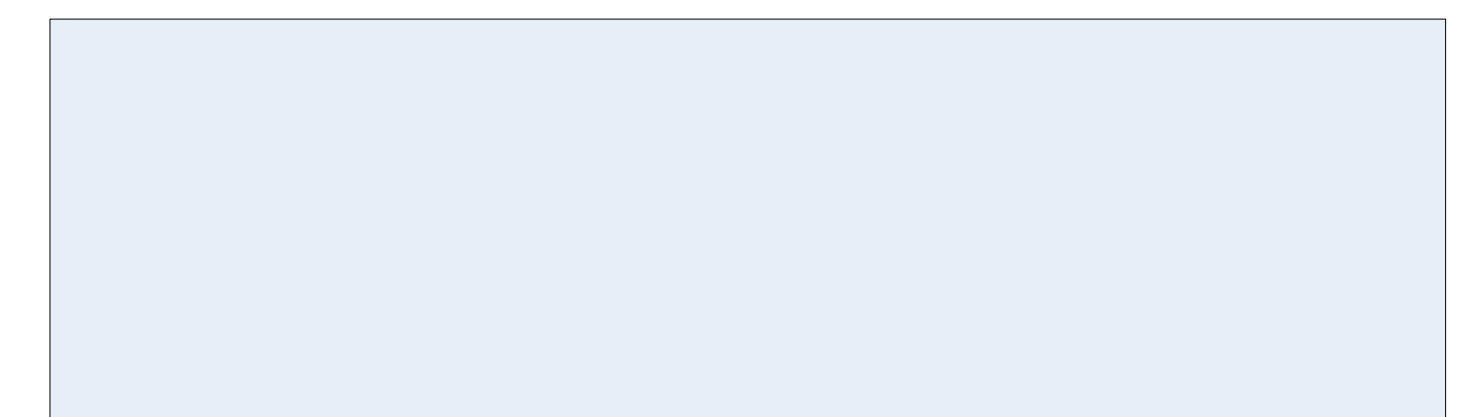

**LIFTING HEIGHT- TOP CRANE INCLUDING BLOCK->**  
**HATCH COAMING**  
**PS=> 40 MTR**  
**SB=> 35,50 MTR**

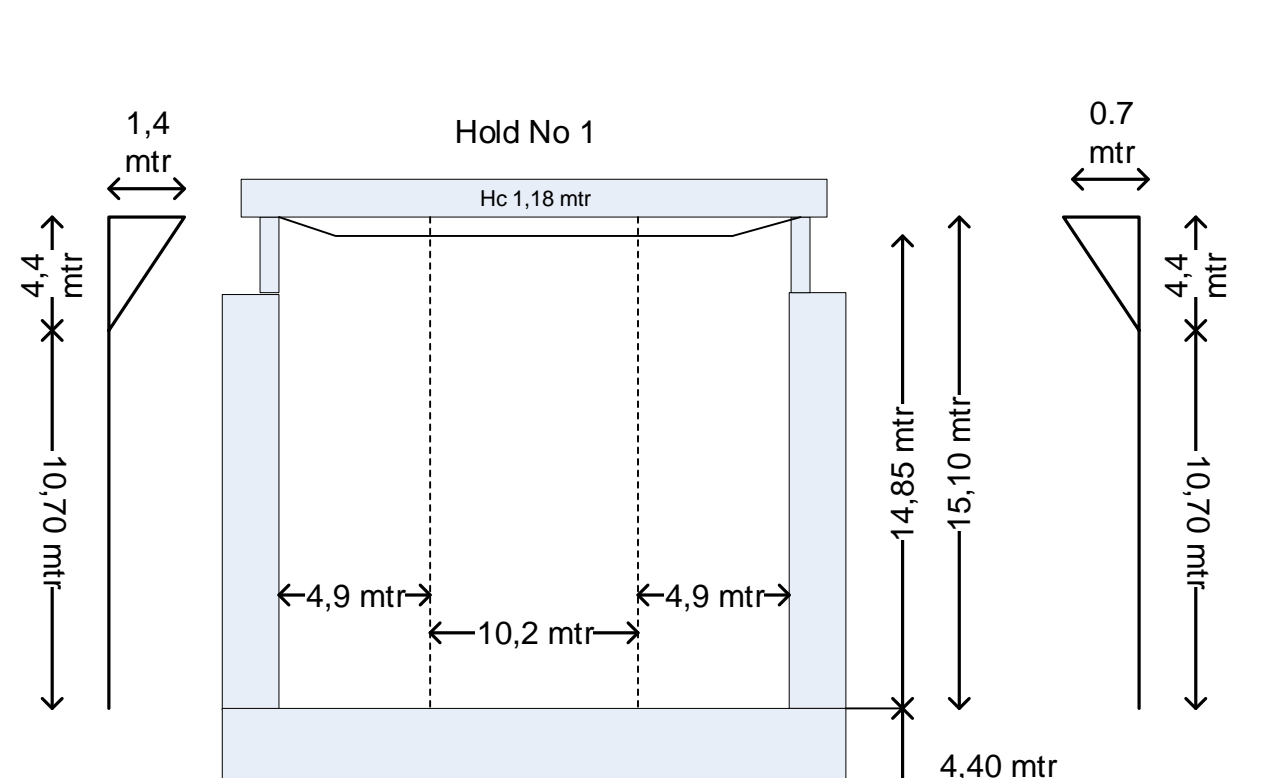
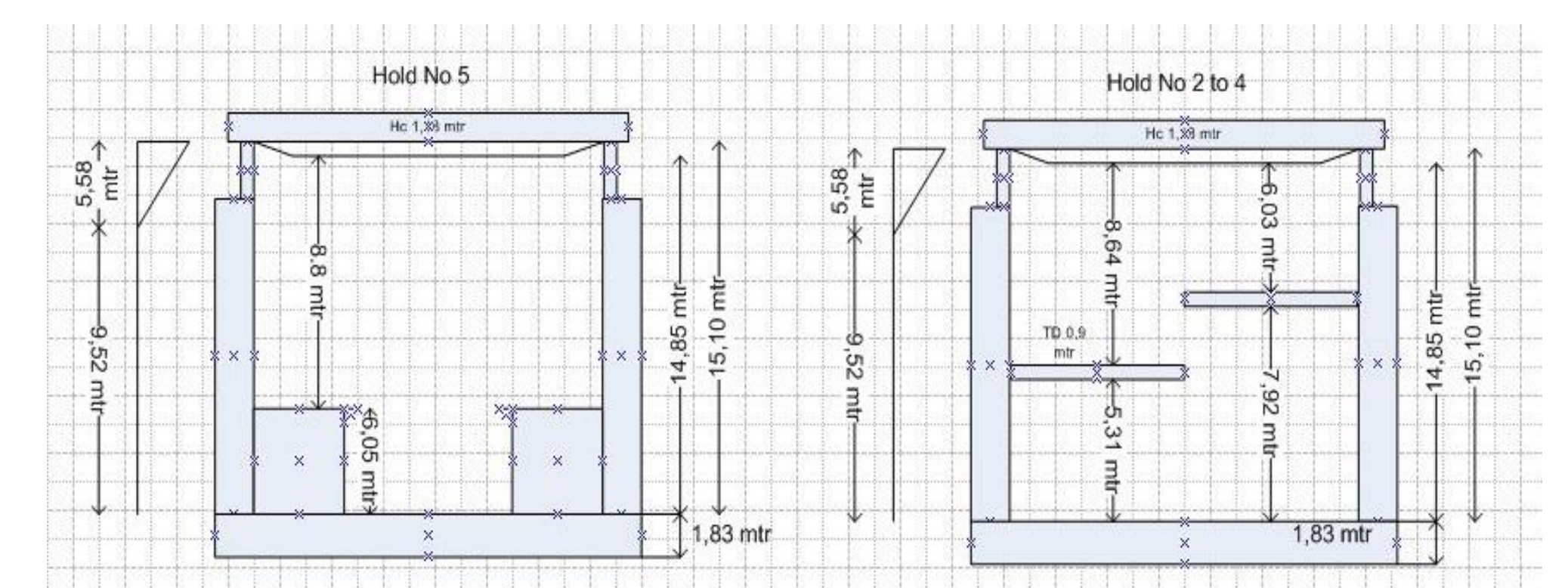
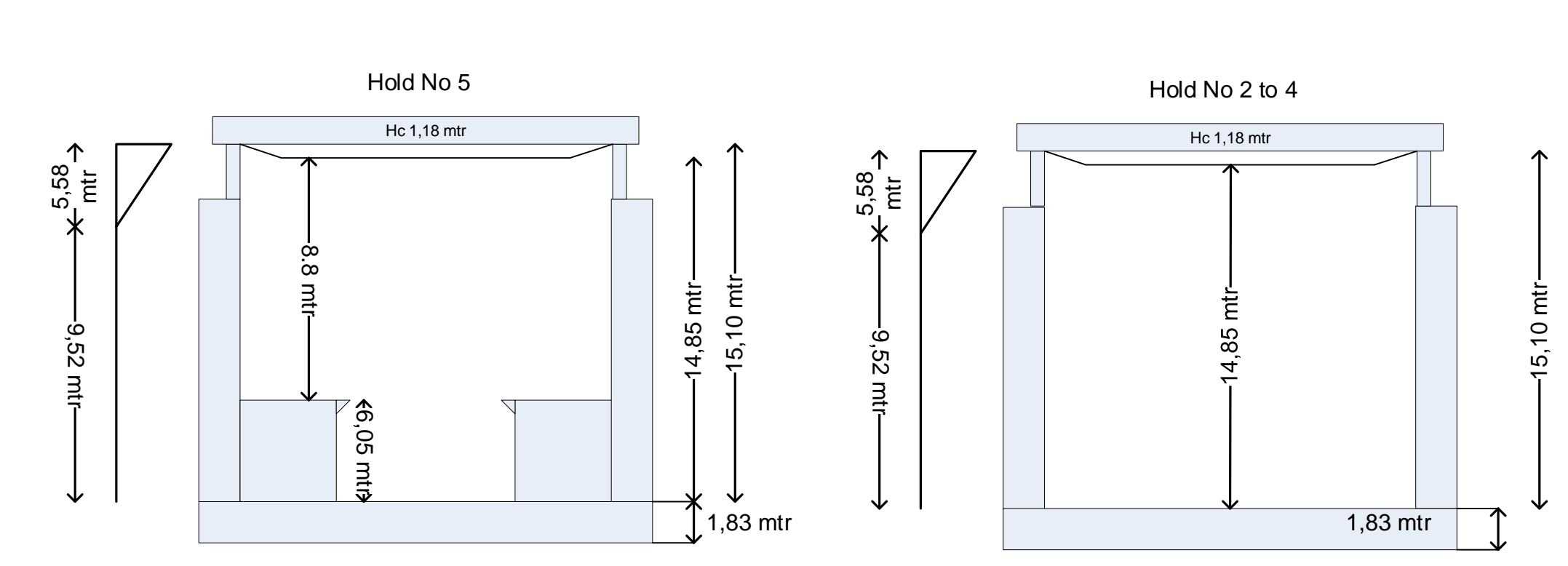
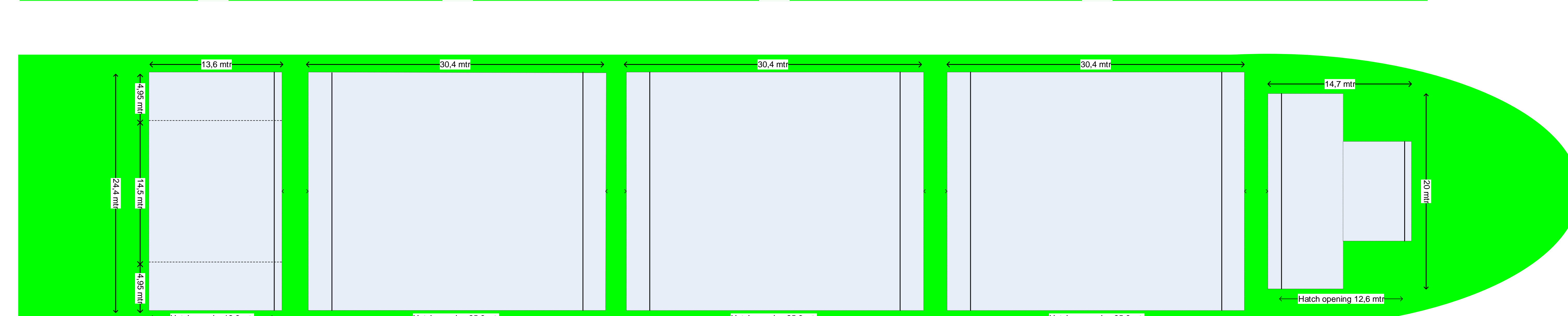
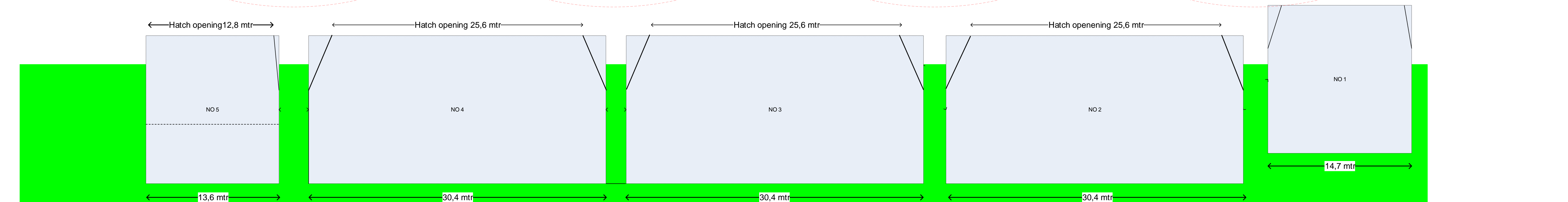
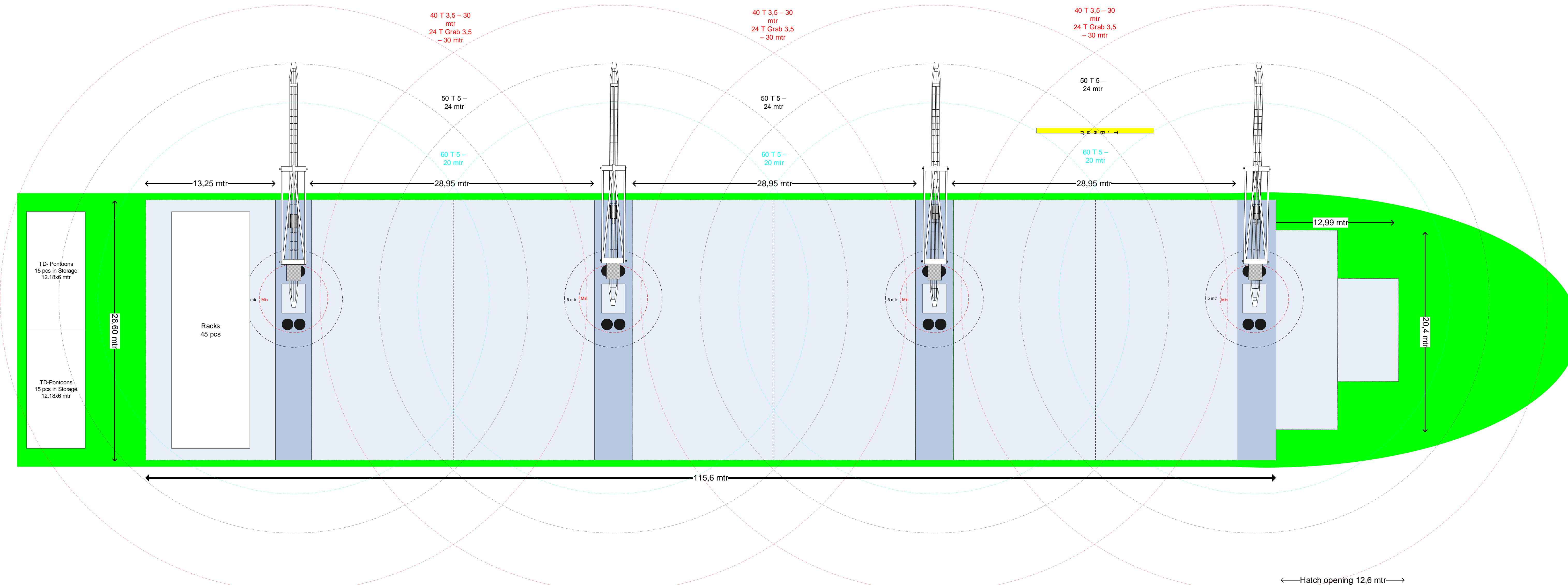

**MV CHIPOL YONGAN**

( presented as tweendecker )

LOA : 179.5 MTR  
LPP : 169.0 MTR  
BR.M: 28.0 MTR  
DRAFT SUMMER: 10.80 MTR

DEADWEIGHT SUMMER :  
32255 MT

**GENERAL LOAD**

TANKTOP : 20 MT/M2

HATCH COVER : 4 MT/M2

**CONTAINER STACK LOAD**

	20'	40'
ABOVE ER	70T	56T
HATCH 1	28T	56T
HATCH 2-5	60T	90T
IN HOLDS	150T	150T

**HOLD CAPACITY**

No 1:	3341	M3
No 2:	10932	M3
No 3-4:	10959	M3
No 5:	4335	M3

T-BEAM : SWL 109 MTR

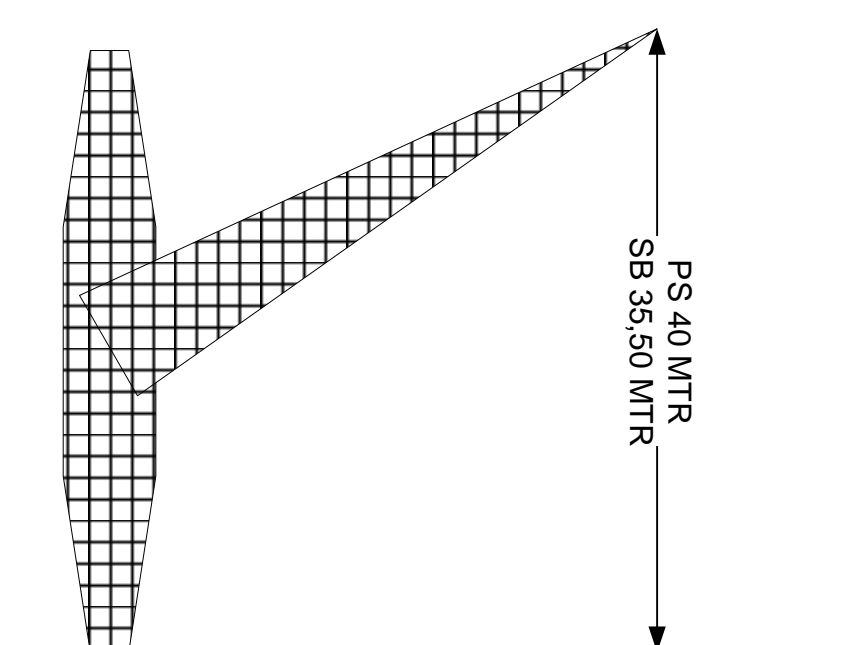
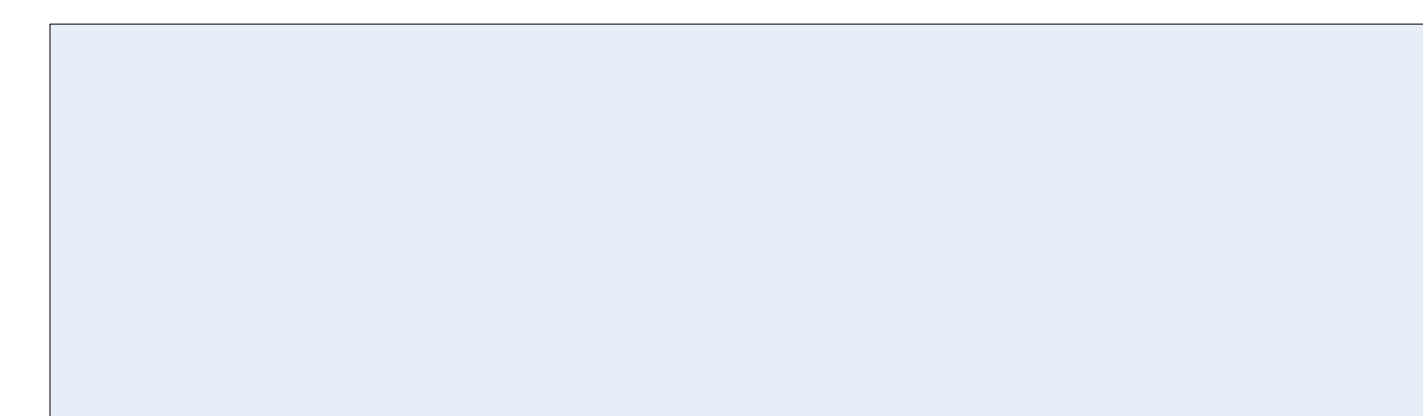

LIFTING HEIGHT- TOP CRANE INCLUDING BLOCK->  
HATCH COAMING  
PS=> 40 MTR  
SB=> 35,50 MTR

