



Port of registry	Hongkong
Flag	Hongkong
Call sign	VRPP6
Official No.	HK-4573
IMO No.	9731377
MMSI	477137300
Vessel Type	General Cargo
Keel laid on	July 13, 2015
Build on	July 05, 2016
Builder	Shanghai Shipyard
Class	LR 100A1

Vessel Owner **CHIPOLBROK PACIFIC SHIPPING COMPANY LTD**

Vessel Operator **CHINESE - POLISH JOINT STOCK SHIPPING COMPANY**

Tonnage	Gross (GT)	Net (NT)
ITC 1969	24478	10305
Panama Canal		
Suez Canal	27761.60	23611.99

PANAMA CANAL ID (ACP ID)	No.
SUEZ CANAL ID (SCID)	No.

Length Overall (LOA)	189.90m
Length between p. (LBP)	184.00m
Breadth moulded	28.00m
Depth moulded	15.50m
Height from keel to the top	52.463m
Height from keel - antenas folded	47.988m

Light Ship	13330.5MT
Constance	320MT
FW allowance	233mm
TPC on summer draft	48.20MT/CM

ME Type	Wartsila 6RT-Flex 50-D
Made by	Hudong Heavy Machinery
Power	8350KW/99RPM
Max Speed	abt. 16.50kn
Service Speed	abt. 15.70kn / 95RPM
Endurance	18000Nm

Fresh water	2 tanks	253.5cbm
Fuel Oil	7tanks	1693.3cbm
Diesel Oil	3tanks	530.4cbm
Ballast Water	28tanks	13357.1cbm

Zone	Draft	Freeboard	Deadweight
TROPIC	10.719m	4.808m	32717.9t
SUMMER	10.500m	5.027m	31660.8t
WINTER	10.281m	5.246m	30607.1t

All above details are given in good faith but not guaranteed. This description may not be used as basis for time charter parties or booking notes. For further information please contact our team rate@chipolbrok.us



Number of Holds	3
Number of Hatches	5
Cargo Capacity Grain	43022.3cbm
Cargo Capacity Bale	39913.1cbm
Container TEU underdeck	891
Container TEU on deck	1028
Total TEU	1919

Hatch cover size Hold 1	25.25x20.56m
Hatch cover size Hold 2 PS	50.56x11.25m
Hatch cover size Hold 2 SB	50.56x11.25m
Hatch cover size Hold 3 PS	50.56x11.25m
Hatch cover size Hold 3 SB	50.56x11.25m
Permissable load - Hatch Cover	3.0t/sqm
Permissable load - Tweendeck	4.0t/sqm
Permissable load - Lower Holds	18.0t/sqm

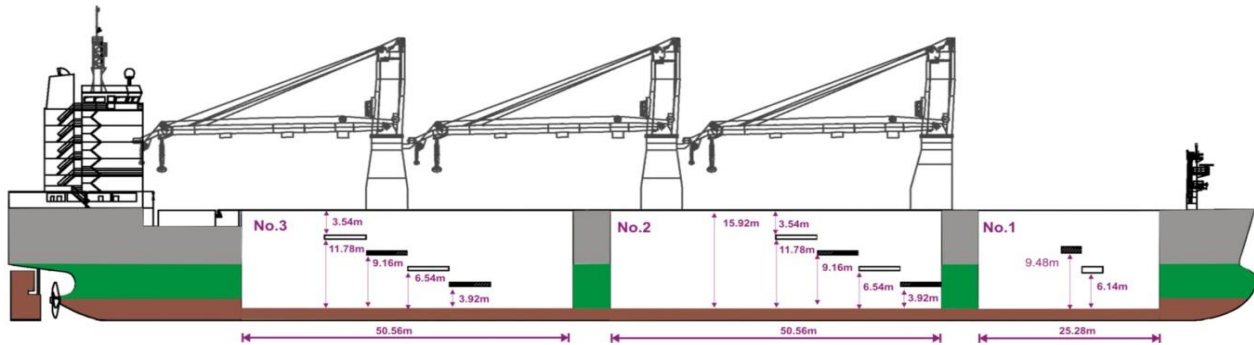

Adjustable tweendecks, box shaped.
Unobrstacted deck space 120 x 20mtr

Cargo Gears	Whip Hook	Main Hook
Crane 1	45t / 36m	350t / 18m - 190t/33m
Crane 2	45t / 36m	350t / 18m - 190t/33m
Crane 3	45t / 36m	350t / 18m - 190t/33m
Crane 1 & Crane 2		Combined 700t / 11m
Crane 2 & Crane 3		Combined 700t / 11m

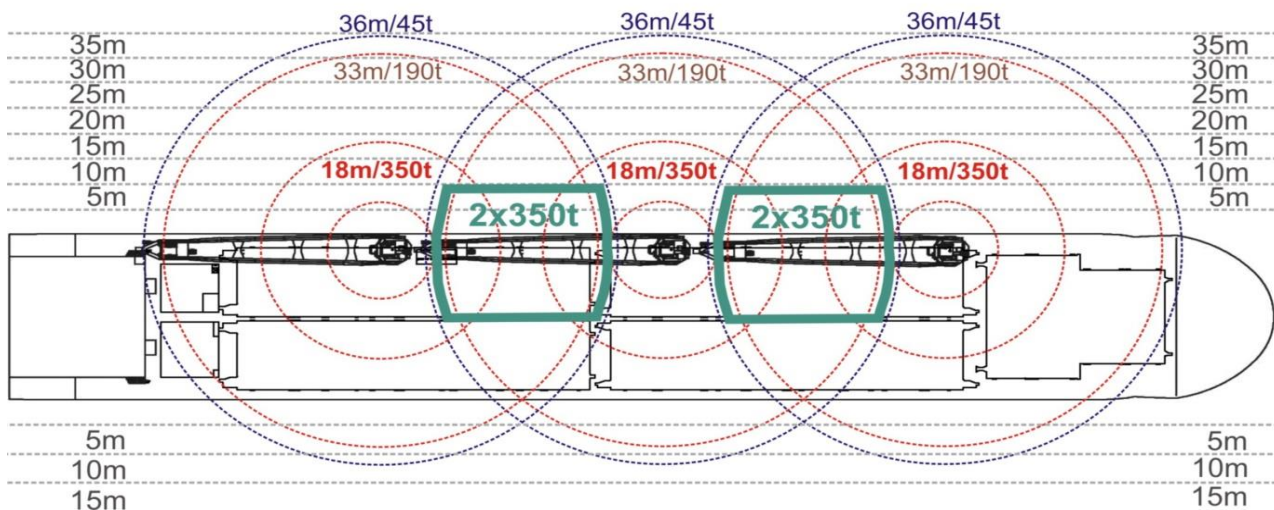

All above details are given in good faith but not guaranteed. This description may not be used as basis for time charter parties or booking notes. For further information please contact our team rate@chipolbrok.us